

## ECO-Skate®

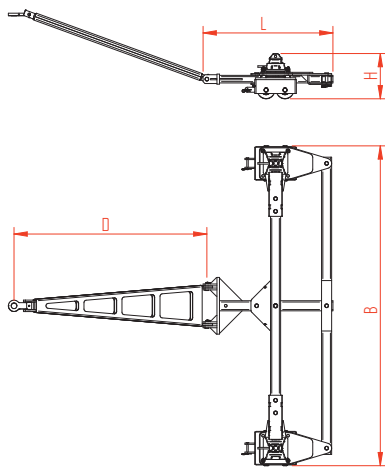

Most flexible Container moving skates, steerable with 90° rotating single wheelbox.



ICFXN20D

Type	ICFXN20D	ICXNS20S**
Capacity* (kg)	10.200.03.36 2x10.000	10.200.03.26 2x10.000
Wheel size (mm)	Ø 140x85	Ø 140x85
Number of wheels	2x4	2x4
Load area (mm)	TLS	TLS
Dimensions (mm) <sup>LxBxH</sup>	1.030x2.536x359 (282)	464x215x359 (282)
Weight (kg)	250	105

\* with PU wheels 2x17.600 kg \*\* not shown

Getinggränd 2 · 275 39 SJÖBO | Bronsyxegatan 9B · 213 75 MALMÖ

Växel 010 – 188 22 00 | WWW.INTERLIFT.SE

VÄND DIG MED FÖRTROENDE TILL INTERLIFT AB -  
ETT STARKT VAL NÄR DET GÄLLER LYFT- OCH MATERIALHANTERING

HTS introduces the newly designed ECO-Skate® ISOCONflex XL container moving system. The versatile ECO-Skate® ISOCONflex XL skate system is ideal for moving ISO containers, even in tight spaces. Whether you need to lift and set from the front or the side of the container, the compact wheel boxes take less space than the typical container skate. With the ISO container fully loaded, the compact wheel boxes can be individually turned 90° to move the container sideways, without the need to lift and reset the skates. With detachable alignment bars and pulling handles, the ECO-Skate® ISOCONflex XL is compact and stores away nicely, taking up less room in your facility.

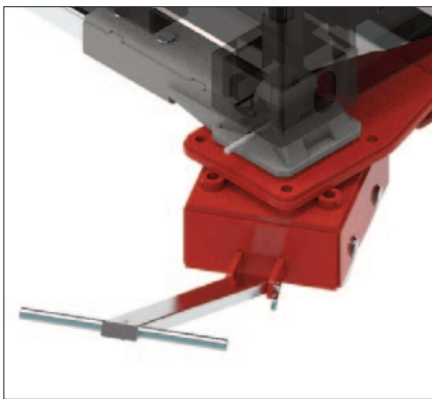

Rotation of the single wheel boxes

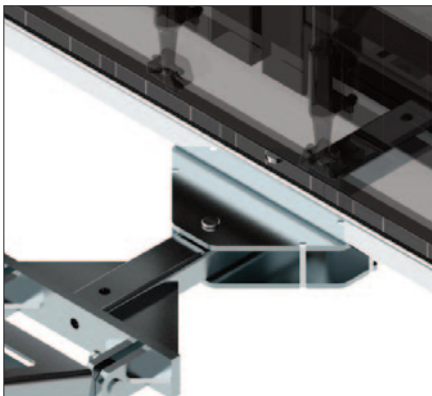
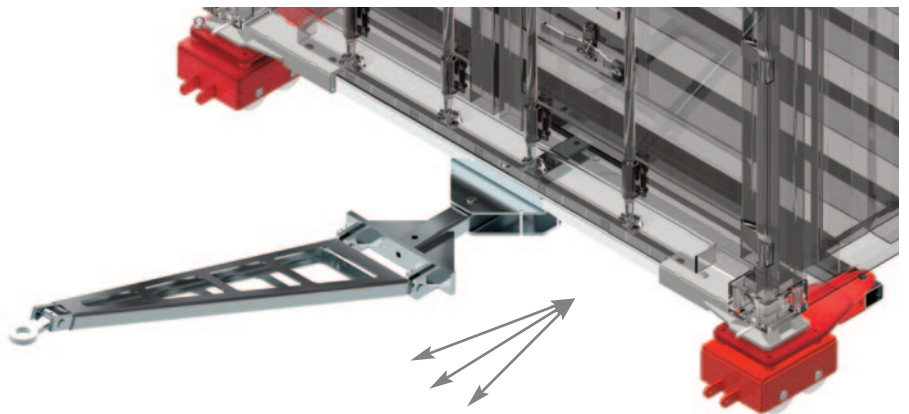

With bolts the steerable skate becomes a fixed rear skate

